

# mTGF-beta-1 ELISA

Enzyme immunoassay for the quantitative determination of mouse TGF- $\beta$ 1 (mTGF- $\beta$ 1) in cell culture supernatants, mouse serum and plasma.

**REF**

**BE45271**



**96**



**2-8 °C**

EU: *For research use only.*

U.S.: *For research use only.  
Not for use in diagnostic procedures.*



**I B L I N T E R N A T I O N A L G M B H**

Flughafenstrasse 52a  
D-22335 Hamburg, Germany

Phone: +49 (0)40-53 28 91-0  
Fax: +49 (0)40-53 28 91-11

IBL@IBL-International.com  
www.IBL-International.com

## TABLE OF CONTENTS

1	Intended Use	1
2	Summary	1
3	Principles of the Test	3
4	Reagents Provided	5
5	Storage Instructions – ELISA Kit	6
6	Specimen Collection and Storage Instructions	6
7	Materials Required But Not Provided	7
8	Precautions for Use	8
9	Preparation of Reagents	9
10	Test Protocol	15
11	Calculation of Results	20
12	Limitations	23
13	Performance Characteristics	23
14	Ordering Information	27
15	Reagent Preparation Summary	28
16	Test Protocol Summary	29

## 1 Intended Use

The mouse TGF- $\beta$ 1 ELISA is an enzyme-linked immunosorbent assay for the quantitative detection of mouse TGF- $\beta$ 1. **The mouse TGF- $\beta$ 1 ELISA is for research use only. Not for diagnostic or therapeutic procedures.**

## 2 Summary

Transforming growth factor- $\beta$  (TGF- $\beta$ ) is a pleiotropic cytokine that exhibits a broad spectrum of biological and regulatory effects on the cellular and organism level. It plays a critical role in cellular growth, development, differentiation, proliferation, extracellular matrix (ECM) synthesis and degradation, control of mesenchymal-epithelial interactions during embryogenesis, immune modulation, apoptosis, cell cycle progression, angiogenesis, adhesion and migration and leukocyte chemotaxis. It has both tumor suppressive and tumor promoting activities and is highly regulated at all levels (e.g.: mRNA turnover, latent protein activation or post-translational modifications).

TGF- $\beta$  is the first recognized protein of at least 40 of the TGF- $\beta$  superfamily of structurally related cytokines.

Three isoforms (TGF- $\beta$  1-3) have been described in mammals. (Each isoform is encoded by a unique gene on different chromosomes. All bind to the same receptors.) They are synthesized by most cell types and tissues. Cells of the immune system mainly express TGF- $\beta$  1.

The initially sequestered, inactive LTGF- $\beta$  (latent TGF- $\beta$ ) requires activation (cleavage and dissociation of its LAP (latency associated peptide) region) before it can exert biological activity. LTGF- $\beta$  can also be bound to LTB (latent TGF- $\beta$  binding protein) to form a large latent complex (LLC). TGF- $\beta$  forms homodimers, and its subunits of 12.5 kDa each are bound via disulphide bridges.

TGF- $\beta$  signal transduction is mediated via the TGF- $\beta$  receptors Type II and I, phosphorylation and conformational changes, followed by different pathways:

SMAD ( - pathway: TGF- $\beta$  recruitment finally leads to phosphorylation of receptor-regulated SMADs (R-SMADs = SMAD 2, 3) and binding of common SMAD (coSMAD = SMAD 4). The R-SMAD/ coSMAD complex enters the nucleus and interacts with a number of transcription factors, coactivators and corepressors.

TGF- $\beta$  induces MAPK- and MAP/ERK kinase dependent signal transduction (JNK/MAPK-, JNK/SPAK-, p38-, ERK1/2 - pathway) and the NF- $\kappa$ B – pathway. TGF- $\beta$  mediates cell cycle growth arrest via the phosphoinositide 3-kinase/Akt pathway.

TGF- $\beta$  signaling is highly regulated e.g. via interaction with inhibitory SMADs (I-SMADs = SMAD 6, 7) or binding of the E3-ubiquitin ligases Smurf1 and Smurf2 or/and coreceptors.

TGF- $\beta$ 1 is the key mediator in the pathophysiology of tissue repair and human fibrogenesis: balance between production and degradation of type I collagen, and fibrosis and scarring in organ and tissue.

TGF- $\beta$ 1 exhibits important immunoregulatory features of partially adverse character: TGF- $\beta$ 1 inhibits B and T cell proliferation, differentiation and antibody production as well as maturation and activation of macrophages. It inhibits activity of NK cells and lymphokine activated killer cells and blocks production of cytokines. TGF- $\beta$ 1 promotes Treg cell differentiation resulting in IL-10/TGF- $\beta$ 1 production and Th1 cell and Th2 cell suppression.

TGF- $\beta$ 1 was recently shown to promote Th17 development in the presence of IL-6 or IL-21 in mice and probably plays a role in human Th17 development together with IL-1 $\beta$ , IL-21 and IL-23. In this context TGF- $\beta$ 1 is involved in induction and mediation of proinflammatory and allergic responses.

### 3 Principles of the Test

An anti-mouse TGF- $\beta$ 1 coating antibody is adsorbed onto microwells.

Mouse TGF- $\beta$ 1 present in the sample or standard binds to antibodies adsorbed to the microwells.

Following incubation unbound biological components are removed during a wash step. A biotin-conjugated anti-mouse TGF- $\beta$ 1 antibody is added and binds to mouse TGF- $\beta$ 1 captured by the first antibody.

Following incubation unbound biotin-conjugated anti-mouse TGF- $\beta$ 1 antibody is removed during a wash step. Streptavidin-HRP is added and binds to the biotin-conjugated anti-mouse TGF- $\beta$ 1 antibody.

Figure 1

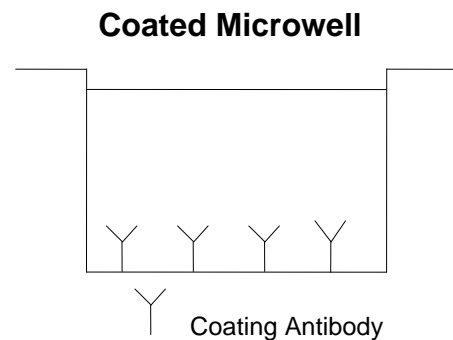

Figure 2

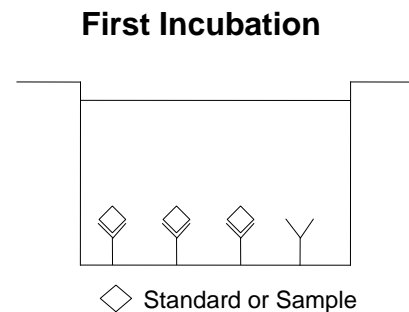

Figure 3

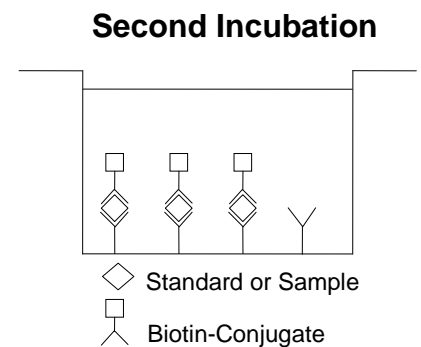
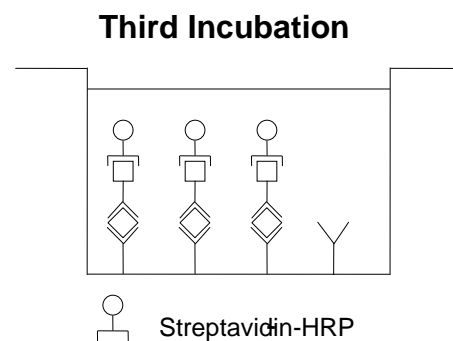
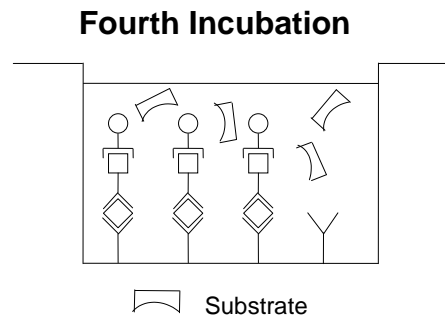

Figure 4



Following incubation unbound Streptavidin-HRP is removed during a wash step, and substrate solution reactive with HRP is added to the wells.

Figure 5



A coloured product is formed in proportion to the amount of mouse TGF- $\beta$ 1 present in the sample or standard. The reaction is terminated by addition of acid and absorbance is measured at 450 nm. A standard curve is prepared from 7 mouse TGF- $\beta$ 1 standard dilutions and mouse TGF- $\beta$ 1 sample concentration determined.

Figure 6

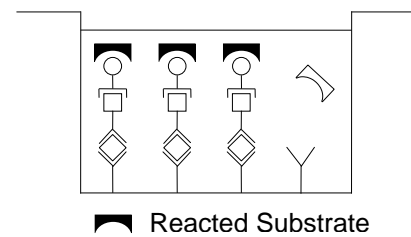

#### 4 Reagents Provided

- 1 aluminium pouch with a **Microwell Plate coated** with monoclonal antibody to mouse TGF- $\beta$ 1
- 1 vial (120  $\mu$ l) **Biotin-Conjugate** anti-mouse TGF- $\beta$ 1 monoclonal antibody
- 1 vial (150  $\mu$ l) **Streptavidin-HRP**
- 2 vials mouse TGF- $\beta$ 1 **Standard** lyophilized, 4 ng/ml upon reconstitution
- 2 vials (5 ml) **Assay Buffer Concentrate 20x** (PBS with 1% Tween 20 and 10% BSA)
- 1 bottle (50 ml) **Wash Buffer Concentrate 20x** (PBS with 1% Tween 20)
- 1 vial (3 ml) 1 N HCl
- 1 vial (3 ml) 1 N NaOH
- 1 vial (15 ml) **Substrate Solution** (tetramethyl-benzidine)
- 1 vial (15 ml) **Stop Solution** (1M Phosphoric acid)
- 1 vial (0.4 ml) **Blue-Dye**
- 1 vial (0.4 ml) **Green-Dye**
- 1 vial (0.4 ml) **Red-Dye**
- 6 **Adhesive Films**

## **5 Storage Instructions – ELISA Kit**

Store kit reagents between 2° and 8°C. Immediately after use remaining reagents should be returned to cold storage (2° to 8°C).

Expiry of the kit and reagents is stated on labels. Expiry of the kit components can only be guaranteed if the components are stored properly, and if, in case of repeated use of one component, this reagent is not contaminated by the first handling.

## **6 Specimen Collection and Storage Instructions**

Cell culture supernatant \*, serum and plasma (EDTA, citrate) were tested with this assay. Other biological samples might be suitable for use in the assay. Remove serum or plasma from the clot or cells as soon as possible after clotting and separation.

Samples containing a visible precipitate must be clarified prior to use in the assay. Do not use grossly hemolyzed or lipemic specimens.

Samples should be aliquoted and must be stored frozen at -20°C to avoid loss of bioactive mouse TGF- $\beta$ 1. If samples are to be run within 24 hours, they may be stored at 2° to 8°C (for sample stability refer to 13.5).

Avoid repeated freeze-thaw cycles. Prior to assay, the frozen sample should be brought to room temperature slowly and mixed gently.

\* Pay attention to a possibly elevated blank signal in cell culture supernatant samples containing serum components (e.g. FCS), due to latent TGF- $\beta$  levels in animal serum.

## **7 Materials Required But Not Provided**

- 5 ml and 10 ml graduated pipettes
- 5  $\mu$ l to 1000  $\mu$ l adjustable single channel micropipettes with disposable tips
- 50  $\mu$ l to 300  $\mu$ l adjustable multichannel micropipette with disposable tips
- Multichannel micropipette reservoir
- Beakers, flasks, cylinders necessary for preparation of reagents
- Device for delivery of wash solution (multichannel wash bottle or automatic wash system)
- Microplate shaker
- Microwell strip reader capable of reading at 450 nm (620 nm as optional reference wave length)
- Glass-distilled or deionized water
- Statistical calculator with program to perform regression analysis

## 8 Precautions for Use

- All chemicals should be considered as potentially hazardous. We therefore recommend that this product is handled only by those persons who have been trained in laboratory techniques and that it is used in accordance with the principles of good laboratory practice. Wear suitable protective clothing such as laboratory overalls, safety glasses and gloves. Care should be taken to avoid contact with skin or eyes. In the case of contact with skin or eyes wash immediately with water. See material safety data sheet(s) and/or safety statement(s) for specific advice.
- Reagents are intended for research use only and are not for use in diagnostic or therapeutic procedures.
- Do not mix or substitute reagents with those from other lots or other sources.
- Do not use kit reagents beyond expiration date on label.
- Do not expose kit reagents to strong light during storage or incubation.
- Do not pipette by mouth.
- Do not eat or smoke in areas where kit reagents or samples are handled.
- Avoid contact of skin or mucous membranes with kit reagents or specimens.
- Rubber or disposable latex gloves should be worn while handling kit reagents or specimens.
- Avoid contact of substrate solution with oxidizing agents and metal.
- Avoid splashing or generation of aerosols.
- In order to avoid microbial contamination or cross-contamination of reagents or specimens which may invalidate the test use disposable pipette tips and/or pipettes.
- Use clean, dedicated reagent trays for dispensing the conjugate and substrate reagent.

- Exposure to acid inactivates the conjugate.
- Glass-distilled water or deionized water must be used for reagent preparation.
- Substrate solution must be at room temperature prior to use.
- Decontaminate and dispose specimens and all potentially contaminated materials as they could contain infectious agents. The preferred method of decontamination is autoclaving for a minimum of 1 hour at 121.5°C.
- Liquid wastes not containing acid and neutralized waste may be mixed with sodium hypochlorite in volumes such that the final mixture contains 1.0% sodium hypochlorite. Allow 30 minutes for effective decontamination. Liquid waste containing acid must be neutralized prior to the addition of sodium hypochlorite.

## 9 Preparation of Reagents

**Buffer Concentrates** should be brought to room temperature and should be diluted before starting the test procedure.

If crystals have formed in the **Buffer Concentrates**, warm them gently until they have completely dissolved.

### 9.1 Wash Buffer (1x)

Pour entire contents (50 ml) of the **Wash Buffer Concentrate** (20x) into a clean 1000 ml graduated cylinder. Bring to final volume of 1000 ml with glass-distilled or deionized water.

Mix gently to avoid foaming.

Transfer to a clean wash bottle and store at 2° to 25°C. Please note that Wash Buffer (1x) is stable for 30 days.

Wash Buffer (1x) may also be prepared as needed according to the following table:

Number of Strips	Wash Buffer Concentrate (20x) (ml)	Distilled Water (ml)
1 - 6	25	475
1 - 12	50	950

### 9.2 Assay Buffer (1x)

Pour the entire contents (5 ml) of the **Assay Buffer Concentrate** (20x) into a clean 100 ml graduated cylinder. Bring to final volume of 100 ml with distilled water. Mix gently to avoid foaming.

Store at 2° to 8°C. Please note that the Assay Buffer (1x) is stable for 30 days.

Assay Buffer (1x) may also be prepared as needed according to the following table:

Number of Strips	Assay Buffer Concentrate (20x) (ml)	Distilled Water (ml)
1 - 6	2.5	47.5
1 - 12	5.0	95.0

### 9.3 Biotin-Conjugate

**Please note that the Biotin-Conjugate should be used within 30 minutes after dilution.**

Make a 1:100 dilution of the concentrated **Biotin-Conjugate** solution with Assay Buffer (1x) in a clean plastic tube as needed according to the following table:

Number of Strips	Biotin-Conjugate (ml)	Assay Buffer (1x) (ml)
1 - 6	0.06	5.94
1 - 12	0.12	11.88

### 9.4 Streptavidin-HRP

**Please note that the Streptavidin-HRP should be used within 30 minutes after dilution.**

Make a 1:100 dilution of the concentrated **Streptavidin-HRP** solution with Assay Buffer (1x) in a clean plastic tube as needed according to the following table:

Number of Strips	Streptavidin-HRP (ml)	Assay Buffer (1x) (ml)
1 - 6	0.06	5.94
1 - 12	0.12	11.88

## 9.5 Mouse TGF- $\beta$ 1 Standard

Reconstitute **mouse TGF- $\beta$ 1 standard** by addition of distilled water. Reconstitution volume is stated on the label of the standard vial. Swirl or mix gently to insure complete and homogeneous solubilization (concentration of reconstituted standard = 4 ng/ml). Allow the standard to reconstitute for 10-30 minutes. Mix well prior to making dilutions.

After usage remaining standard cannot be stored and has to be discarded.

**Standard dilutions** can be prepared directly on the microwell plate (see 10.d) or alternatively in tubes (see 9.5.1).

### 9.5.1 External Standard Dilution

Label 7 tubes, one for each standard point.

S1, S2, S3, S4, S5, S6, S7

Then prepare 1:2 serial dilutions for the standard curve as follows:  
Pipette 225  $\mu$ l of Assay Buffer (1x) into each tube.

Pipette 225  $\mu$ l of diluted standard (concentration of standard = 4000 pg/ml) into the first tube, labelled S1, and mix (concentration of standard 1 = 2 ng/ml).

Pipette 225  $\mu$ l of this dilution into the second tube, labelled S2, and mix thoroughly before the next transfer.

Repeat serial dilutions 5 more times thus creating the points of the standard curve (see Figure 7).

Assay Buffer (1x) serves as blank.

Figure 7

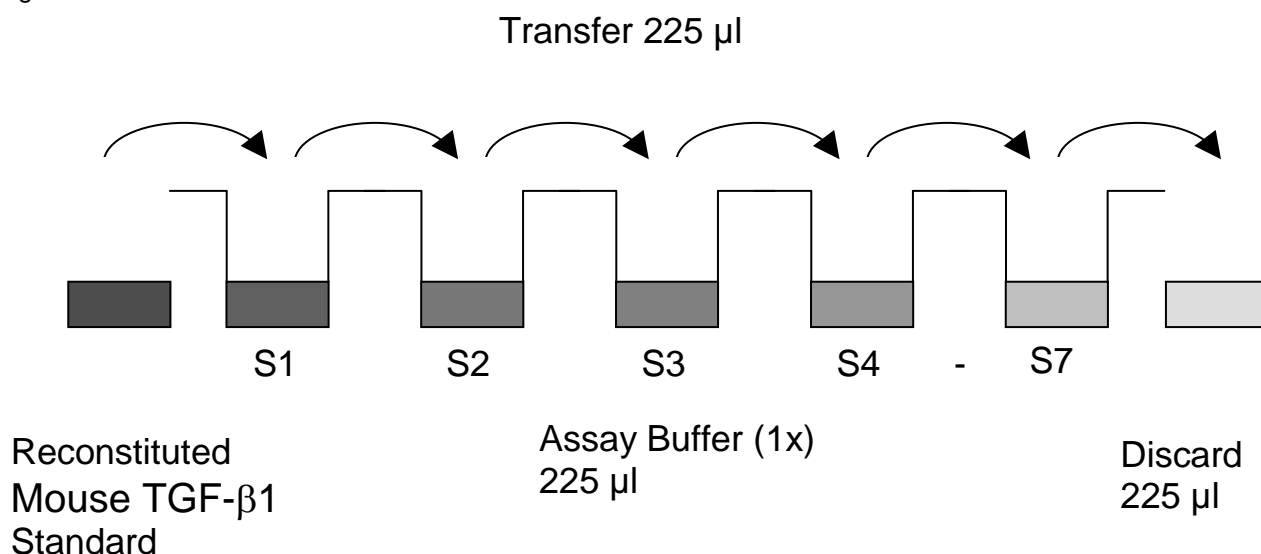

## 9.6 Addition of Colour-giving Reagents: Blue-Dye, Green-Dye, Red-Dye

In order to help our customers to avoid any mistakes in pipetting IBL ELISAs, we offers a tool that helps to monitor the addition of even very small volumes of a solution to the reaction well by giving distinctive colours to each step of the ELISA procedure.

**This procedure is optional**, does not in any way interfere with the test results, and is designed to help the customer with the performance of the test, but can also be omitted, just following the instruction booklet.

Alternatively, the dye solutions from the stocks provided (**Blue-Dye, Green-Dye, Red-Dye**) can be added to the reagents according to the following guidelines:

- 1. Diluent:** Before standard dilution add the **Blue-Dye** at a dilution of 1:250 (see table below) to the appropriate diluent (1x) according to the test protocol. After addition of **Blue-Dye**, proceed according to the instruction booklet.

5 ml Assay Buffer (1x)	20 $\mu$ l <b>Blue-Dye</b>
12 ml Assay Buffer (1x)	48 $\mu$ l <b>Blue-Dye</b>
50 ml Assay Buffer (1x)	200 $\mu$ l <b>Blue-Dye</b>

- 2. Biotin-Conjugate:** Before dilution of the concentrated Biotin-Conjugate, add the **Green-Dye** at a dilution of

1:100 (see table below) to the Assay Buffer (1x) used for the final conjugate dilution. Proceed after addition of **Green-Dye** according to the instruction booklet: Preparation of Biotin-Conjugate.

3 ml Assay Buffer (1x)	30 µl <b>Green-Dye</b>
6 ml Assay Buffer (1x)	60 µl <b>Green-Dye</b>
12 ml Assay Buffer (1x)	120 µl <b>Green-Dye</b>

**3. Streptavidin-HRP:** Before dilution of the concentrated Streptavidin-HRP, add the **Red-Dye** at a dilution of 1:250 (see table below) to the Assay Buffer (1x) used for the final Streptavidin-HRP dilution. Proceed after addition of **Red-Dye** according to the instruction booklet: Preparation of Streptavidin-HRP.

6 ml Assay Buffer (1x)	24 µl <b>Red-Dye</b>
12 ml Assay Buffer (1x)	48 µl <b>Red-Dye</b>

## 10 Test Protocol

- a. Prepare your serum and plasma samples before starting the test procedure. Dilute serum and plasma samples with Assay Buffer (1x) according to the following scheme:  
 20  $\mu$ l sample + 920  $\mu$ l Assay Buffer (1x)  
 Add 30  $\mu$ l 1N HCl to 940  $\mu$ l prediluted sample, mix and incubate for 1 hour at room temperature.  
 Neutralize by addition of 30  $\mu$ l 1N NaOH.

Prepare your cell culture supernatant samples before starting the test procedure. Dilute cell culture supernatant samples with Assay Buffer (1x) according to the following scheme:  
 20  $\mu$ l sample + 180  $\mu$ l Assay Buffer (1x)  
 Add 20  $\mu$ l 1N HCl to 200  $\mu$ l prediluted sample, mix and incubate for 1 hour at room temperature.  
 Neutralize by addition of 20  $\mu$ l 1N NaOH.

Sample Matrix	Sample Volume ( $\mu$ l)	Assay Buffer (1x) ( $\mu$ l)	HCl 1N ( $\mu$ l)	NaOH 1N ( $\mu$ l)	Predilution
Serum and Plasma	20	920	30	30	1:50
Cell culture supernatant	20	180	20	20	1:12

- b. Determine the number of microwell strips required to test the desired number of samples plus appropriate number of wells needed for running blanks and standards. Each sample, standard, blank and optional control sample should be assayed in duplicate. Remove extra microwell strips from holder and store in foil bag with the desiccant provided at 2°-8°C sealed tightly.
- c. Wash the microwell strips twice with approximately 400  $\mu$ l **Wash Buffer** per well with thorough aspiration of microwell contents between washes. Allow the Wash Buffer to sit in the wells for about **10 – 15 seconds** before aspiration. Take care not to scratch the surface of the microwells.

After the last wash step, empty wells and tap microwell strips on absorbent pad or paper towel to remove excess Wash Buffer. Use the microwell strips immediately after washing. Alternatively microwell strips can be placed upside down on a wet absorbent paper for not longer than 15 minutes. **Do not allow wells to dry.**

- d. **Standard dilution on the microwell plate** (Alternatively the standard dilution can be prepared in tubes – see 9.5.1):  
 Add 100  $\mu$ l of Assay Buffer (1x) in duplicate to all **standard wells**. Pipette 100  $\mu$ l of prepared **standard** (see Preparation of Standard 9.5, concentration = 4000.0 pg/ml) in duplicate into well A1 and A2 (see Table 1). Mix the contents of wells A1 and A2 by repeated aspiration and ejection (concentration of standard 1, S1 = 2000.0 pg/ml), and transfer 100  $\mu$ l to wells B1 and B2, respectively (see Figure 8). Take care not to scratch the inner surface of the microwells. Continue this procedure 5 times, creating two rows of mouse TGF- $\beta$ 1 standard dilutions ranging from 2000.0 to 31.3 pg/ml. Discard 100  $\mu$ l of the contents from the last microwells (G1, G2) used.

Figure 8

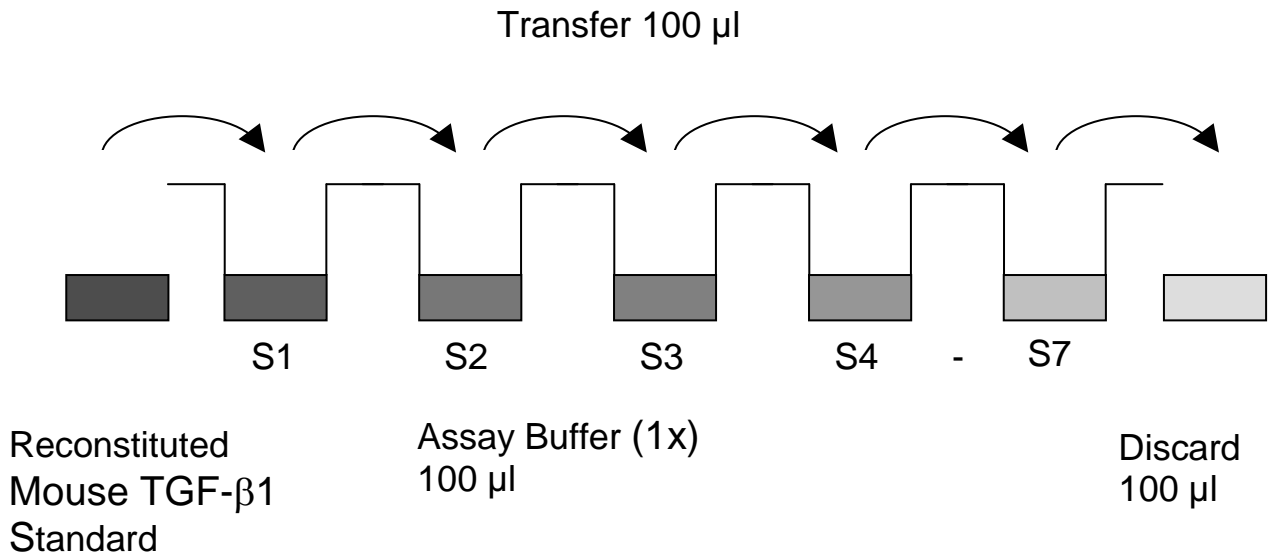

In case of an **external standard dilution** (see 9.5.1), pipette 100  $\mu$ l of these standard dilutions (S1 - S7) in the standard wells according to Table 1.

Table 1

Table depicting an example of the arrangement of blanks, standards and samples in the microwell strips:

	<b>1</b>	<b>2</b>	<b>3</b>	<b>4</b>
<b>A</b>	Standard 1 (2000.0 pg/ml)	Standard 1 (2000.0 pg/ml)	Sample 1	Sample 1
<b>B</b>	Standard 2 (1000.0 pg/ml)	Standard 2 (1000.0 pg/ml)	Sample 2	Sample 2
<b>C</b>	Standard 3 (500.0 pg/ml)	Standard 3 (500.0 pg/ml)	Sample 3	Sample 3
<b>D</b>	Standard 4 (250.0 pg/ml)	Standard 4 (250.0 pg/ml)	Sample 4	Sample 4
<b>E</b>	Standard 5 (125.0 pg/ml)	Standard 5 (125.0 pg/ml)	Sample 5	Sample 5
<b>F</b>	Standard 6 (62.5 pg/ml)	Standard 6 (62.5 pg/ml)	Sample 6	Sample 6
<b>G</b>	Standard 7 (31.3 pg/ml)	Standard 7 (31.3 pg/ml)	Sample 7	Sample 7
<b>H</b>	Blank	Blank	Sample 8	Sample 8

- e. Add 100  $\mu$ l of **Assay Buffer (1x)** in duplicate to the **blank wells**.
- f. For serum and plasma samples add 80  $\mu$ l of **Assay Buffer (1x)** to the **sample wells**.  
For cell culture supernatant samples add 60  $\mu$ l of **Assay Buffer (1x)** to the **sample wells**.
- g. For serum and plasma samples add 20  $\mu$ l of each pretreated **sample** in duplicate to the **sample wells**.  
For cell culture supernatant samples add 40  $\mu$ l of each pretreated **sample** in duplicate to the **sample wells**.
- h. Cover with an adhesive film and incubate at room temperature (18 to 25°C) for 2 hours, on a microplate shaker set at 400 rpm. (**Shaking is absolutely necessary for an optimal test performance.**)
- i. Prepare **Biotin-Conjugate** (see Preparation of Biotin-Conjugate 9.3).
- j. Remove adhesive film and empty wells. **Wash** microwell strips 5 times according to point c. of the test protocol. Proceed immediately to the next step.
- k. Add 100  $\mu$ l of **Biotin-Conjugate** to all wells.
- l. Cover with an adhesive film and incubate at room temperature (18 to 25°C) for 1 hour, on a microplate shaker set at 400 rpm. (**Shaking is absolutely necessary for an optimal test performance.**)
- m. Prepare **Streptavidin-HRP** (refer to Preparation of Streptavidin-HRP 9.4).
- n. Remove adhesive film and empty wells. **Wash** microwell strips 5 times according to point c. of the test protocol. Proceed immediately to the next step.
- o. Add 100  $\mu$ l of diluted **Streptavidin-HRP** to all wells, including the blank wells.
- p. Cover with an adhesive film and incubate at room temperature (18° to 25°C) for 30 minutes, on a microplate shaker set at 400 rpm. (**Shaking is absolutely necessary for an optimal test performance.**)

- q. Remove adhesive film and empty wells. **Wash** microwell strips 5 times according to point c. of the test protocol. Proceed immediately to the next step.
- r. Pipette 100 µl of **TMB Substrate Solution** to all wells.
- s. Incubate the microwell strips at room temperature (18° to 25°C) for **about 30 min.** Avoid direct exposure to intense light.

**The colour development on the plate should be monitored and the substrate reaction stopped (see next point of this protocol) before positive wells are no longer properly recordable. Determination of the ideal time period for colour development has to be done individually for each assay.**

It is recommended to add the stop solution when the highest standard has developed a dark blue colour. Alternatively the colour development can be monitored by the ELISA reader at 620 nm. The substrate reaction should be stopped as soon as Standard 1 has reached an OD of 0.9 – 0.95.

- t. Stop the enzyme reaction by quickly pipetting 100 µl of **Stop Solution** into each well. It is important that the Stop Solution is spread quickly and uniformly throughout the microwells to completely inactivate the enzyme. Results must be read immediately after the Stop Solution is added or within one hour if the microwell strips are stored at 2 - 8°C in the dark.
- u. Read absorbance of each microwell on a spectro-photometer using 450 nm as the primary wave length (optionally 620 nm as the reference wave length; 610 nm to 650 nm is acceptable). Blank the plate reader according to the manufacturer's instructions by using the blank wells. Determine the absorbance of both the samples and the standards.

## 11 Calculation of Results

- Calculate the average absorbance values for each set of duplicate standards and samples. Duplicates should be within 20 per cent of the mean value.
- Create a standard curve by plotting the mean absorbance for each standard concentration on the ordinate against the mouse TGF- $\beta$ 1 concentration on the abscissa. Draw a best fit curve through the points of the graph (a 5-parameter curve fit is recommended).
- To determine the concentration of circulating mouse TGF- $\beta$ 1 for each sample, first find the mean absorbance value on the ordinate and extend a horizontal line to the standard curve. At the point of intersection, extend a vertical line to the abscissa and read the corresponding mouse TGF- $\beta$ 1 concentration.
- **If instructions in this protocol have been followed serum and plasma samples have been diluted 1:250 (20  $\mu$ l sample + 920  $\mu$ l Assay Buffer (1x) (= 1:50) + 30 $\mu$ l 1N HCl + 30 $\mu$ l 1N NaOH and 20  $\mu$ l pretreated sample + 80  $\mu$ l Assay Buffer (1x) (= 1:5)) and cell culture supernatant samples have been diluted 1:30 (20  $\mu$ l sample + 180  $\mu$ l Assay Buffer (1x) + 20 $\mu$ l 1N HCl + 20 $\mu$ l 1N NaOH (= 1:12) and 40  $\mu$ l pretreated sample + 60  $\mu$ l Assay Buffer (1x) (= 1:2.5)), the concentration read from the standard curve must be multiplied by the dilution factor (x 250 or 30, respectively).**
- **Calculation of samples with a concentration exceeding standard 1 may result in incorrect, low mouse TGF- $\beta$ 1 levels. Such samples require further external predilution according to expected mouse TGF- $\beta$ 1 values with Assay Buffer (1x) in order to precisely quantitate the actual mouse TGF- $\beta$ 1 level.**
- It is suggested that each testing facility establishes a control sample of known mouse TGF- $\beta$ 1 concentration and runs this additional control with each assay. If the values obtained are not within the expected range of the control, the assay results may be invalid.
- A representative standard curve is shown in Figure 9. This curve cannot be used to derive test results. Each laboratory must prepare a standard curve for each group of microwell strips assayed.

Figure 9

Representative standard curve for mouse TGF- $\beta$ 1 ELISA. Mouse TGF- $\beta$ 1 was diluted in serial 2-fold steps in Assay Buffer (1x). Do not use this standard curve to derive test results. A standard curve must be run for each group of microwell strips assayed.

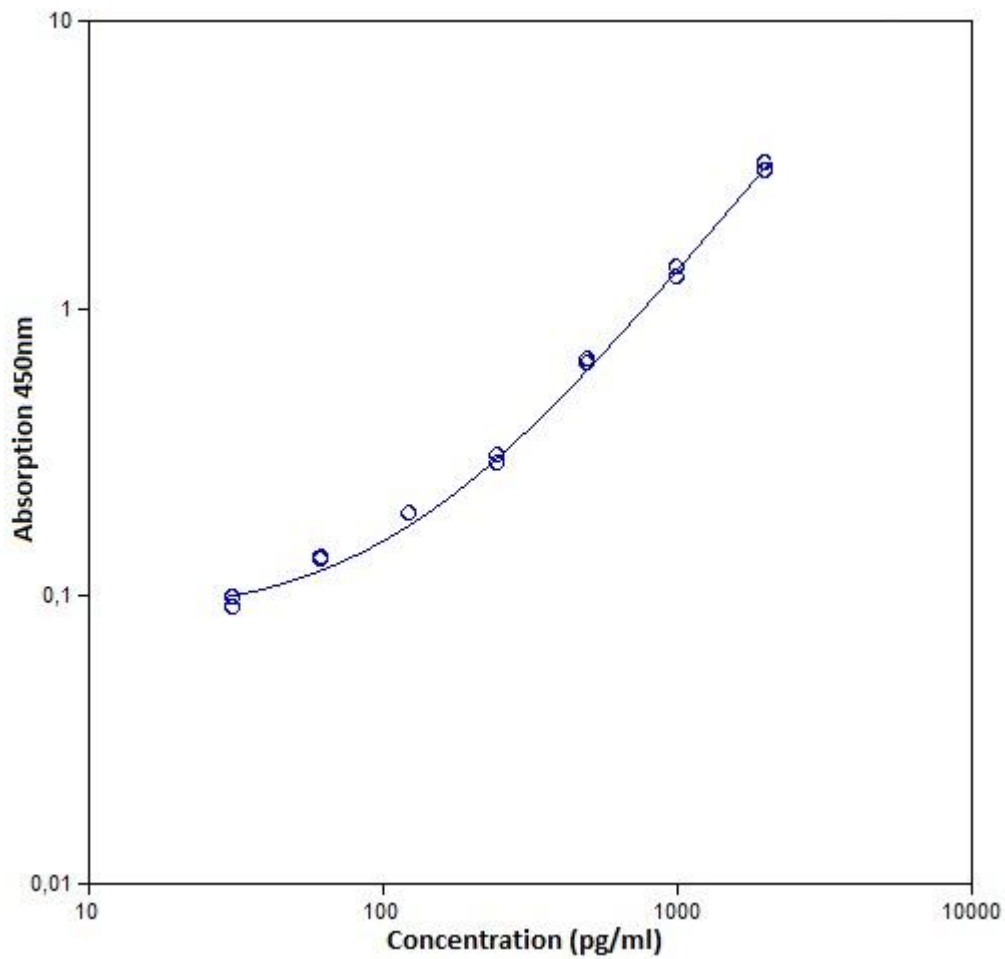

Table 2

Typical data using the mouse TGF- $\beta$ 1 ELISA

Measuring wavelength: 450 nm

Reference wavelength: 620 nm

Standard	Mouse TGF- $\beta$ 1 Concentration (pg/ml)	O.D. at 450 nm	Mean O.D. at 450 nm	C.V. (%)
1	2000.0	2.979 3.178	3.069	4.1
2	1000.0	1.363 1.257	1.319	4.7
3	500.0	0.636 0.651	0.644	1.6
4	250.0	0.306 0.287	0.297	4.5
5	125.0	0.191 0.191	0.191	0
6	62.5	0.133 0.135	0.134	1.1
7	31.3	0.09 0.098	0.094	6.0
Blank	0	0.056 0.058	0.057	2.5

The OD values of the standard curve may vary according to the conditions of assay performance (e.g. operator, pipetting technique, washing technique or temperature effects). Furthermore shelf life of the kit may affect enzymatic activity and thus colour intensity. Values measured are still valid.

## 12 Limitations

- Since exact conditions may vary from assay to assay, a standard curve must be established for every run.
- Bacterial or fungal contamination of either screen samples or reagents or cross-contamination between reagents may cause erroneous results.
- Disposable pipette tips, flasks or glassware are preferred, reusable glassware must be washed and thoroughly rinsed of all detergents before use.
- Improper or insufficient washing at any stage of the procedure will result in either false positive or false negative results. Empty wells completely before dispensing fresh wash solution, fill with Wash Buffer as indicated for each wash cycle and do not allow wells to sit uncovered or dry for extended periods.

## 13 Performance Characteristics

### 13.1 Sensitivity

The limit of detection of mouse TGF- $\beta$ 1 defined as the analyte concentration resulting in an absorbance significantly higher than that of the dilution medium (mean plus 2 standard deviations) was determined to be 7.8 pg/ml (mean of 6 independent assays).

### 13.2 Reproducibility

#### 13.2.1 Intra-assay

Reproducibility within the assay was evaluated in 3 independent experiments. Each assay was carried out with 6 replicates of 4 serum samples containing different concentrations of mouse TGF- $\beta$ 1. 2 standard curves were run on each plate. Data below show the mean mouse TGF- $\beta$ 1 concentration and the coefficient of variation for each sample (see Table 3). The calculated overall intra-assay coefficient of variation was 7.9%.

Table 3

The mean mouse TGF- $\beta$ 1 concentration and the coefficient of variation for each sample

Sample	Experiment	Mean Mouse TGF- $\beta$ 1 Concentration (pg/ml)	Coefficient of Variation (%)
1	1	84911	6.0%
	2	84794	2.1%
	3	90031	4.0%
2	1	71109	9.8%
	2	72589	7.1%
	3	87214	3.9%
3	1	83062	2.7%
	2	82381	2.0%
	3	73504	12.3%
4	1	40048	13.4%
	2	40078	17.5%
	3	41075	14.1%

### 13.2.2 Inter-assay

Assay to assay reproducibility within one laboratory was evaluated in 3 independent experiments. Each assay was carried out with 6 replicates of 4 serum plasma samples containing different concentrations of mouse TGF- $\beta$ 1. 2 standard curves were run on each plate. Data below show the mean mouse TGF- $\beta$ 1 concentration and the coefficient of variation calculated on 18 determinations of each sample (see Table 4). The calculated overall inter-assay coefficient of variation was 5.8%.

Table 4

The mean mouse TGF- $\beta$ 1 concentration and the coefficient of variation of each sample

Sample	Mean Mouse TGF- $\beta$ 1 Concentration (pg/ml)	Coefficient of Variation (%)
1	86579	3.5%
2	76970	11.6%
3	79649	6.7%
4	40400	1.4%

### 13.3 Spike Recovery

The spike recovery was evaluated by spiking 3 levels of mouse TGF- $\beta$ 1 into serum, plasma and cell culture supernatant. Recoveries were determined with 4 replicates each.

The amount of endogenous mouse TGF- $\beta$ 1 in unspiked samples was subtracted from the spike values.

For recovery data see Table 5.

Table 5

Sample matrix	Spike high (%)	Spike medium (%)	Spike low (%)
Serum	85	99	99
Plasma (EDTA)	81	83	73
Plasma (citrate)	96	89	97
Cell culture supernatant	87	85	95

### 13.4 Dilution Parallelism

Serum, plasma and cell culture supernatant samples with different levels of mouse TGF- $\beta$ 1 were analysed at serial 2 fold dilutions with 4 replicates each. For recovery data see Table 6.

Table 6

Sample matrix	Recovery of Exp. Val.	
	Range (%)	Mean (%)
Serum	89 - 119	103
Plasma (EDTA)	90 - 115	100
Plasma (citrate)	81 - 109	94
Cell culture supernatant	-	105

## **13.5 Sample Stability**

### **13.5.1 Freeze-Thaw Stability**

Aliquots of serum samples (spiked or unspiked) were stored at -20°C and thawed 5 times, and the mouse TGF- $\beta$ 1 levels determined. There was no significant loss of mouse TGF- $\beta$ 1 immunoreactivity detected by freezing and thawing.

### **13.5.2 Storage Stability**

Aliquots of serum samples (spiked or unspiked) were stored at -20°C, 2-8°C and room temperature (RT), and the mouse TGF- $\beta$ 1 level determined after 24 h. There was no significant loss of mouse TGF- $\beta$ 1 immunoreactivity detected during storage under above conditions.

## **13.6 Specificity**

The assay detects both natural and recombinant mouse TGF- $\beta$ 1. The cross reactivity of TGF- $\beta$ 2 and TGF- $\beta$ 3, and of TNF- $\beta$ , IL-8, IL-6, IL-2, TNF- $\alpha$ , IL-1 $\beta$ , IL-4, IFN- $\gamma$ , IL12p70, IL-5 and IL-10 was evaluated by spiking these proteins at physiologically relevant concentrations into serum. There was no cross reactivity detected.

## **14 Ordering Information**

For orders please contact:

**See last page**

For technical information please contact:

e-mail: [IBL@IBL-International.com](mailto:IBL@IBL-International.com)  
**[www.IBL-International.com](http://www.IBL-International.com)**

## 15 Reagent Preparation Summary

### 15.1 Wash Buffer (1x)

Add **Wash Buffer Concentrate** 20x (50 ml) to 950 ml distilled water.

Number of Strips	Wash Buffer Concentrate (ml)	Distilled Water (ml)
1 - 6	25	475
1 - 12	50	950

### 15.2 Assay Buffer (1x)

Add **Assay Buffer Concentrate** 20x (5 ml) to 95 ml distilled water.

Number of Strips	Assay Buffer Concentrate (ml)	Distilled Water (ml)
1 - 6	2.5	47.5
1 - 12	5.0	95.0

### 15.3 Biotin-Conjugate

Make a 1:100 dilution of **Biotin-Conjugate** in Assay Buffer (1x):

Number of Strips	Biotin-Conjugate (ml)	Assay Buffer (1x) (ml)
1 - 6	0.06	5.94
1 - 12	0.12	11.88

### 15.4 Streptavidin-HRP

Make a 1:100 dilution of **Streptavidin-HRP** in Assay Buffer (1x):

Number of Strips	Streptavidin-HRP (ml)	Assay Buffer (1x) (ml)
1 - 6	0.06	5.94
1 - 12	0.12	11.88

### 15.5 Mouse TGF- $\beta$ 1 Standard

Reconstitute lyophilized **mouse TGF- $\beta$ 1 standard** with distilled water. (Reconstitution volume is stated on the label of the standard vial.).

## 16 Test Protocol Summary

1. Pretreatment for serum and plasma samples: 20 µl sample + 920 µl Assay Buffer (1x), add 30 µl 1N HCl to 940 µl prediluted sample, mix and incubate for 1 hour at room temperature, add 30 µl 1N NaOH; Pretreatment for cell culture supernatant samples: 20 µl sample + 180 µl Assay Buffer (1x), add 20 µl 1N HCl to 200 µl prediluted sample, mix and incubate for 1 hour at room temperature, add 20 µl 1N NaOH;
2. Determine the number of microwell strips required.
3. Wash microwell strips twice with Wash Buffer.
4. Standard dilution on the microwell plate: Add 100 µl Assay Buffer (1x), in duplicate, to all standard wells. Pipette 100 µl prepared standard into the first wells and create standard dilutions by transferring 100 µl from well to well. Discard 100 µl from the last wells. Alternatively external standard dilution in tubes (see 9.5.1): Pipette 100 µl of these standard dilutions in the microwell strips.
5. Add 100 µl Assay Buffer (1x), in duplicate, to the blank wells.
6. Add 80 µl (serum and plasma samples) or 60 µl (cell culture supernatant samples) Assay Buffer (1x) to sample wells.
7. Add 20 µl (serum or plasma sample) or 40 µl (cell culture supernatant sample) in duplicate, to designated sample wells.
8. Cover microwell strips and incubate 2 hours at room temperature (Shaking is absolutely necessary for an optimal test performance.)
9. Prepare Biotin-Conjugate.
10. Empty and wash microwell strips 5 times with Wash Buffer.
11. Add 100 µl Biotin-Conjugate to all wells.
12. Cover microwell strips and incubate 1 hours at room temperature. (Shaking is absolutely necessary for an optimal test performance.)
13. Prepare Streptavidin-HRP.
14. Empty and wash microwell strips 5 times with Wash Buffer.
15. Add 100 µl diluted Streptavidin-HRP to all wells.
16. Cover microwell strips and incubate 30 minutes at room temperature. (Shaking is absolutely necessary for an optimal test performance.)
17. Empty and wash microwell strips 5 times with Wash Buffer.
18. Add 100 µl of TMB Substrate Solution to all wells.
19. Incubate the microwell strips for **about 30 minutes** at room temperature
20. Add 100 µl Stop Solution to all wells.
21. Blank microwell reader and measure colour intensity at 450 nm.

**Note: If instructions in this protocol have been followed samples have been diluted 1:250 (serum and plasma) or 1:30 (cell culture supernatant), the concentration read from the standard curve must be multiplied by the dilution factor (x 250 or 30, respectively).**

# Symbols / Symbole / Symbôles / Símbolos / Símbolos / Σύμβολα

	Cat.-No.: / Kat.-Nr.: / No.- Cat.: / Cat.-No.: / N.º Cat.: / N.-Cat.: / Αριθμός-Κατ.:
	Lot-No.: / Chargen-Bez.: / No. Lot: / Lot-No.: / Lote N.º: / Lotto n.: / Αριθμός -Παραγωγή:
	Use by: / Verwendbar bis: / Utiliser à: / Usado por: / Usar até: / Da utilizzare entro: / Χρησιμοποιείται από:
	No. of Tests: / Kitgröße: / Nb. de Tests: / No. de Determ.: / N.º de Testes: / Quantità dei tests: / Αριθμός εξετάσεων:
	Concentrate / Konzentrat / Concentré / Concentrar / Concentrado / Concentrato / Συμπύκνωμα
	Lyophilized / Lyophilisat / Lyophilisé / Liofilizado / Liofilizado / Liofilizzato / Λυοφιλιασμένο
	In Vitro Diagnostic Medical Device. / In-vitro-Diagnostikum. / Appareil Médical pour Diagnostics In Vitro. / Dispositivo Médico para Diagnóstico In Vitro. / Equipamento Médico de Diagnóstico In Vitro. / Dispositivo Medico Diagnostico In vitro. / Ιατρική συσκευή για In-Vitro Διάγνωση.
	Evaluation kit. / Nur für Leistungsbewertungszwecke. / Kit pour évaluation. / Juego de Reactivos para Evaluació. / Kit de avaliação. / Kit di valutazione. / Κιτ Αξιολόγησης.
	Read instructions before use. / Arbeitsanleitung lesen. / Lire la fiche technique avant emploi. / Lea las instrucciones antes de usar. / Ler as instruções antes de usar. / Leggere le istruzioni prima dell'uso. / Διαβάστε τις οδηγίες πριν την χρήση.
	Keep away from heat or direct sun light. / Vor Hitze und direkter Sonneneinstrahlung schützen. / Garder à l'abri de la chaleur et de toute exposition lumineuse. / Manténgase alejado del calor o la luz solar directa. / Manter longe do calor ou luz solar directa. / Non esporre ai raggi solari. / Να φυλάσσεται μακριά από θερμότητα και άμεση επαφή με το φως του ηλίου.
	Store at: / Lagern bei: / Stocker à: / Almacene a: / Armazenar a: / Conservare a: / Αποθήκευση στους:
	Manufacturer: / Hersteller: / Fabricant: / Productor: / Fabricante: / Fabricante: / Παραγωγός:
	Caution! / Vorsicht! / Attention! / ¡Precaución! / Cuidado! / Attenzione! / Προσοχή!
<p>Symbols of the kit components see MATERIALS SUPPLIED.  Die Symbole der Komponenten sind im Kapitel KOMPONENTEN DES KITS beschrieben.  Voir MATERIEL FOURNI pour les symbôles des composants du kit.  Símbolos de los componentes del juego de reactivos, vea MATERIALES SUMINISTRADOS.  Para símbolos dos componentes do kit ver MATERIAIS FORNECIDOS.  Per i simboli dei componenti del kit si veda COMPONENTI DEL KIT.  Για τα σύμβολα των συστατικών του κιτ συμβουλευτείτε το ΠΑΡΕΧΟΜΕΝΑ ΥΛΙΚΑ.</p>	

## IBL AFFILIATES WORLDWIDE

	<b>IBL International GmbH</b> Flughafenstr. 52A, 22335 Hamburg, Germany	Tel.: + 49 (0) 40 532891 -0 Fax: -11 E-MAIL: IBL@IBL-International.com WEB: <a href="http://www.IBL-International.com">http://www.IBL-International.com</a>
	<b>IBL International Corp.</b> 194 Wildcat Road, Toronto, Ontario M3J 2N5, Canada	Tel.: +1 (416) 645 -1703 Fax: -1704 E-MAIL: Sales@IBL-International.com WEB: <a href="http://www.IBL-International.com">http://www.IBL-International.com</a>

**LIABILITY:** Complaints will be accepted in each mode –written or vocal. Preferred is that the complaint is accompanied with the test performance and results. Any modification of the test procedure or exchange or mixing of components of different lots could negatively affect the results. These cases invalidate any claim for replacement. Regardless, in the event of any claim, the manufacturer's liability is not to exceed the value of the test kit. Any damage caused to the kit during transportation is not subject to the liability of the manufacturer