

# sVEGF-R1 ELISA

Enzyme immunoassay for the quantitative determination of soluble VEGF-R1 in human cell culture supernatant, serum, plasma and other biological samples.

**REF** **BE59131**



**1 x 96**



For research use only.  
Not for use in diagnostic procedures.



**I B L I N T E R N A T I O N A L G M B H**

Flughafenstrasse 52a  
D-22335 Hamburg, Germany

Phone: +49 (0)40-53 28 91-0  
Fax: +49 (0)40-53 28 91-11

IBL@IBL-International.com  
www.IBL-International.com

**1 Intended Use**

The human VEGF-R1 ELISA is an enzyme-linked immunosorbent assay for the quantitative detection of human VEGF-R1. For research use only. Not for diagnostic or therapeutic procedures.

**2 Summary**

Soluble VEGF-R1 (sFLT-1) is a naturally occurring endogenous form of the VEGF-R1 and was originally found in the supernatant of human vascular endothelial cells. It is generated by differential splicing of the flt-1 gene. In vitro VEGF-R1 is used to inhibit VEGF-A mediated signals in endothelial cells and in vivo it can be used to block physiological angiogenesis in several organs, e.g. in the ovary or in bones. Tumor cells transfected with the flt-1 gene are growth restricted in vivo because of the limitation in developing tumor blood vessels via VEGF-A signalling. Very recent studies have shown that this molecule is present endogenously at ng/mL concentrations in biological fluids of normal human subjects or in the conditioned media of FLT-1 positive cell types.

**3 Principles of the Test**

An anti-human VEGF-R1 coating antibody is adsorbed onto microwells.

Figure 1

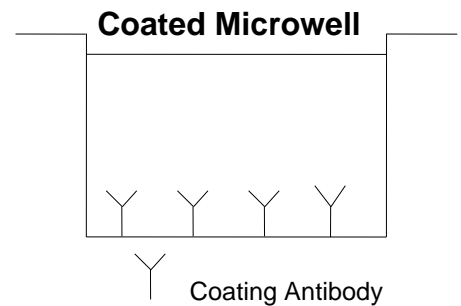

Human VEGF-R1 present in the sample or standard binds to antibodies adsorbed to the microwells. A biotin-conjugated anti-human VEGF-R1 antibody is added and binds to human VEGF-R1 captured by the first antibody.

Figure 2

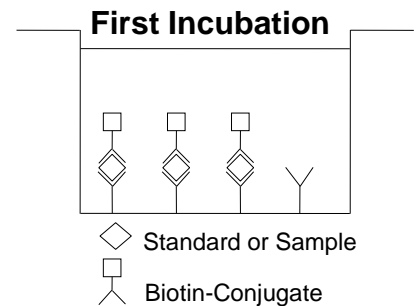

Following incubation unbound biotin-conjugated anti-human VEGF-R1 antibody is removed during a wash step. Streptavidin-HRP is added and binds to the biotin-conjugated anti-human VEGF-R1 antibody.

Figure 3

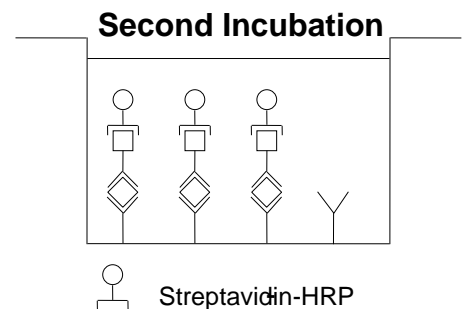

Following incubation unbound Streptavidin-HRP is removed during a wash step, and substrate solution reactive with HRP is added to the wells.

Figure 4

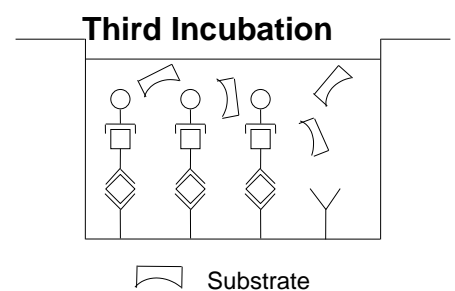

A colored product is formed in proportion to the amount of human VEGF-R1 present in the sample or standard. The reaction is terminated by addition of acid and absorbance is measured at 450 nm. A standard curve is prepared from 7 human VEGF-R1 standard dilutions and human VEGF-R1 sample concentration determined.

Figure 5

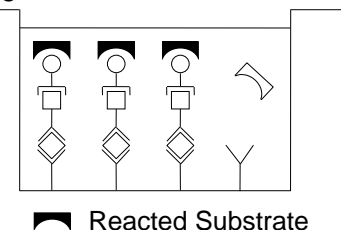

#### 4 Reagents Provided

<b>MTP</b>	1 aluminium pouch with a <b>Microwell Plate</b> coated with monoclonal antibody to human VEGF-R1
<b>BIOTIN CONC</b>	1 vial (70 µL) <b>Biotin-Conjugate</b> anti-human VEGF-R1 polyclonal antibody
<b>ENZCONJ CONC</b>	1 vial (150 µL) <b>Streptavidin-HRP</b>
<b>CAL LYO</b>	2 vials human VEGF-R1 <b>Standard</b> lyophilized, 20 ng/mL upon reconstitution
<b>SUBS</b>	1 vial (15 mL) <b>Substrate Solution</b> (tetramethyl-benzidine)
<b>WASHBUF CONC</b>	1 bottle (50 mL) <b>Wash Buffer Concentrate</b> 20x (PBS with 1% Tween 20)
<b>STOP</b>	1 vial (15 mL) <b>Stop Solution</b> (1M Phosphoric acid)
<b>CONJDIL</b>	1 bottle (20 mL) <b>Conjugate Diluent</b>
<b>ASSAYBUF CONC</b>	1 vial (5 mL) <b>Assay Buffer Concentrate</b> 20x (PBS with 1% Tween 20, 10% BSA)

#### 4 Adhesive Films

#### 5 Storage Instructions – ELISA Kit

Store kit reagents between 2°C and 8°C. Immediately after use remaining reagents should be returned to cold storage (2°C to 8°C). Expiry of the kit and reagents is stated on labels.

Expiry of the kit components can only be guaranteed if the components are stored properly, and if, in case of repeated use of one component, this reagent is not contaminated by the first handling.

#### 6 Specimen Collection and Storage Instructions

Cell culture supernatant, serum and plasma (EDTA, citrate), were tested with this assay. Other biological samples might be suitable for use in the assay. Remove serum or plasma from the clot or cells as soon as possible after clotting and separation.

Pay attention to a possible “Hook Effect” due to high sample concentrations (see chapter 11).

Samples containing a visible precipitate must be clarified prior to use in the assay. Do not use grossly hemolyzed or lipemic specimens.

Samples should be aliquoted and must be stored frozen at -20°C to avoid loss of bioactive human VEGF-R1. If samples are to be run within 24 hours, they may be stored at 2°C to 8°C (for sample stability refer to 13.5).

Avoid repeated freeze-thaw cycles. Prior to assay, the frozen sample should be brought to room temperature slowly and mixed gently.

## 7 Materials Required But Not Provided

- 5 mL and 10 mL graduated pipettes
- 5 µL to 1000 µL adjustable single channel micropipettes with disposable tips
- 50 µL to 300 µL adjustable multichannel micropipette with disposable tips
- Multichannel micropipette reservoir
- Beakers, flasks, cylinders necessary for preparation of reagents
- Device for delivery of wash solution (multichannel wash bottle or automatic wash system)
- Microwell strip reader capable of reading at 450 nm (620 nm as optional reference wave length)
- Glass-distilled or deionized water
- Statistical calculator with program to perform regression analysis

## 8 Precautions for Use

- All chemicals should be considered as potentially hazardous. We therefore recommend that this product is handled only by those persons who have been trained in laboratory techniques and that it is used in accordance with the principles of good laboratory practice. Wear suitable protective clothing such as laboratory overalls, safety glasses and gloves. Care should be taken to avoid contact with skin or eyes. In the case of contact with skin or eyes wash immediately with water. See material safety data sheet(s) and/or safety statement(s) for specific advice.
- Reagents are intended for research use only and are not for use in diagnostic or therapeutic procedures.
- Do not mix or substitute reagents with those from other lots or other sources.
- Do not use kit reagents beyond expiration date on label.
- Do not expose kit reagents to strong light during storage or incubation.
- Do not pipet by mouth.
- Do not eat or smoke in areas where kit reagents or samples are handled.
- Avoid contact of skin or mucous membranes with kit reagents or samples.
- Rubber or disposable latex gloves should be worn while handling kit reagents or samples.
- Avoid contact of substrate solution with oxidizing agents and metal.
- Avoid splashing or generation of aerosols.
- To avoid microbial contamination or cross-contamination of reagents or samples that may invalidate the test, use disposable pipette tips and/or pipettes.
- Use clean, dedicated reagent trays for dispensing the conjugate and substrate reagent.
- Exposure to acid inactivates the conjugate.
- Glass-distilled water or deionized water must be used for reagent preparation.
- Substrate solution must be at room temperature prior to use.
- Decontaminate and dispose samples and all potentially contaminated materials as if they could contain infectious agents. The preferred method of decontamination is autoclaving for a minimum of 1 hour at 121.5°C.
- Liquid wastes not containing acid and neutralized waste may be mixed with sodium hypochlorite in volumes such that the final mixture contains 1.0% sodium hypochlorite. Allow 30 minutes for effective decontamination. Liquid waste containing acid must be neutralized prior to the addition of sodium hypochlorite.

## 9 Preparation of Reagents

1. Buffer Concentrates should be brought to room temperature and should be diluted before starting the test procedure.
2. If crystals have formed in the Buffer Concentrates, warm them gently until they have completely dissolved.

### 9.1 Wash Buffer (1x)

1. Pour entire contents (50 mL) of the Wash Buffer Concentrate (20x) into a clean 1000 mL graduated cylinder. Bring to final volume of 1000 mL with glass-distilled or deionized water. Mix gently to avoid foaming.
2. Transfer to a clean wash bottle and store at 2°C to 25°C. Please note that Wash Buffer (1x) is stable for 30 days.
3. Wash Buffer (1x) may also be prepared as needed according to the following table:

Number of Strips	Wash Buffer Concentrate (20x) (mL)	Distilled Water (mL)
1 - 6	25	475
1 - 12	50	950

### 9.1 Assay Buffer (1x)

1. Pour the entire contents (5 mL) of the Assay Buffer Concentrate (20x) into a clean 100 mL graduated cylinder. Bring to final volume of 100 mL with distilled water. Mix gently to avoid foaming.
2. Store at 2°C to 8°C. Please note that the Assay Buffer (1x) is stable for 30 days.
3. Assay Buffer (1x) may also be prepared as needed according to the following table:

Number of Strips	Assay Buffer Concentrate (20x) (mL)	Distilled Water (mL)
1 - 6	2.5	47.5
1 - 12	5.0	95.0

### 9.2 Biotin-Conjugate

Note: The Biotin-Conjugate should be used within 30 minutes after dilution.

Make a 1:100 dilution of the concentrated Biotin-Conjugate solution with Conjugate Diluent in a clean plastic tube as needed according to the following table:

Number of Strips	Biotin-Conjugate (mL)	Conjugate Diluent (mL)
1 - 6	0.03	2.97
1 - 12	0.06	5.94

### 9.3 Streptavidin-HRP

Note: The Streptavidin-HRP should be used within 30 minutes after dilution.

Make a 1:300 dilution of the concentrated Streptavidin-HRP solution with Conjugate Diluent in a clean plastic tube as needed according to the following table:

Number of Strips	Streptavidin-HRP (mL)	Conjugate Diluent (mL)
1 - 6	0.02	5.98
1 - 12	0.04	11.96

### 9.4 Human VEGF-R1 Standard

1. Reconstitute human VEGF-R1 standard by addition of distilled water. Reconstitution volume is stated on the label of the standard vial. Swirl or mix gently to insure complete and homogeneous solubilisation (concentration of reconstituted standard = 20.00 ng/mL).
2. Allow the standard to reconstitute for 10-30 minutes. Mix well prior to making dilutions.
3. After usage remaining standard cannot be stored and has to be discarded. The standard has to be used immediately after reconstitution and cannot be stored.

### 9.4.1 External Standard Dilution

1. Label 7 tubes, one for each standard point: S1, S2, S3, S4, S5, S6, S7
2. Prepare 1:2 serial dilutions for the standard curve as follows:  
Pipette 225  $\mu$ L of Assay Buffer (1x) into each tube.
3. Pipette 225  $\mu$ L of reconstituted standard (concentration of standard = 20 ng/mL) into the first tube, labeled S1, and mix (concentration of standard 1 = 10 ng/mL).
4. Pipette 225  $\mu$ L of this dilution into the second tube, labeled S2, and mix thoroughly before the next transfer.
5. Repeat serial dilutions 5 more times thus creating the points of the standard curve (see Figure 6).  
Assay Buffer (1x) serves as blank.

Figure 6

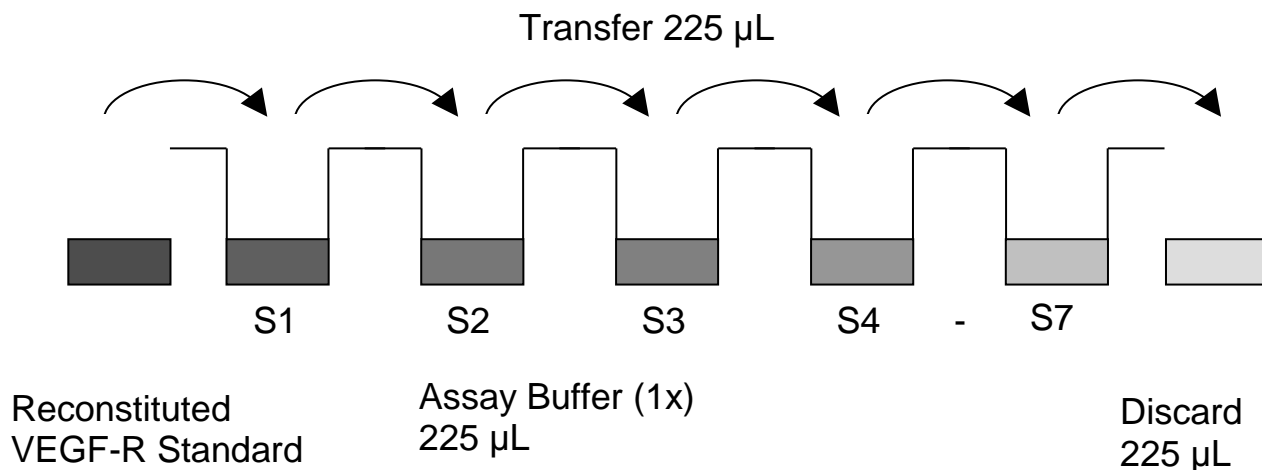

## 10 Test Protocol

- a. Determine the number of microwell strips required to test the desired number of samples plus appropriate number of wells needed for running blanks and standards. Each sample, standard, blank and optional control sample should be assayed in duplicate. Remove extra microwell strips from holder and store in foil bag with the desiccant provided at 2°-8°C sealed tightly.
- b. Wash the microwell strips twice with approximately 400  $\mu$ L Wash Buffer per well with thorough aspiration of microwell contents between washes. Allow the Wash Buffer to sit in the wells for about 10 – 15 seconds before aspiration. Take care not to scratch the surface of the microwells. After the last wash step, empty wells and tap microwell strips on absorbent pad or paper towel to remove excess Wash Buffer. Use the microwell strips immediately after washing. Alternatively microwell strips can be placed upside down on a wet absorbent paper for not longer than 15 minutes. Do not allow wells to dry.
- c. Standard dilution on the microwell plate  
(Alternatively the standard dilution can be prepared in tubes - see 9.4.1.):  
Add 100  $\mu$ L of Assay Buffer (1x) in duplicate to all standard wells. Pipette 100  $\mu$ L of prepared standard (see Preparation of Standard 9.4, concentration = 20.00 ng/mL) in duplicate into well A1 and A2 (see Table 1). Mix the contents of wells A1 and A2 by repeated aspiration and ejection (concentration of standard 1, S1 = 10.00 ng/mL), and transfer 100  $\mu$ L to wells B1 and B2, respectively (see Figure 7). Take care not to scratch the inner surface of the microwells. Continue this procedure 5 times, creating two rows of human VEGF-R1 standard dilutions ranging from 10.00 to 0.16 ng/mL. Discard 100  $\mu$ L of the contents from the last microwells (G1, G2) used.

Figure 7

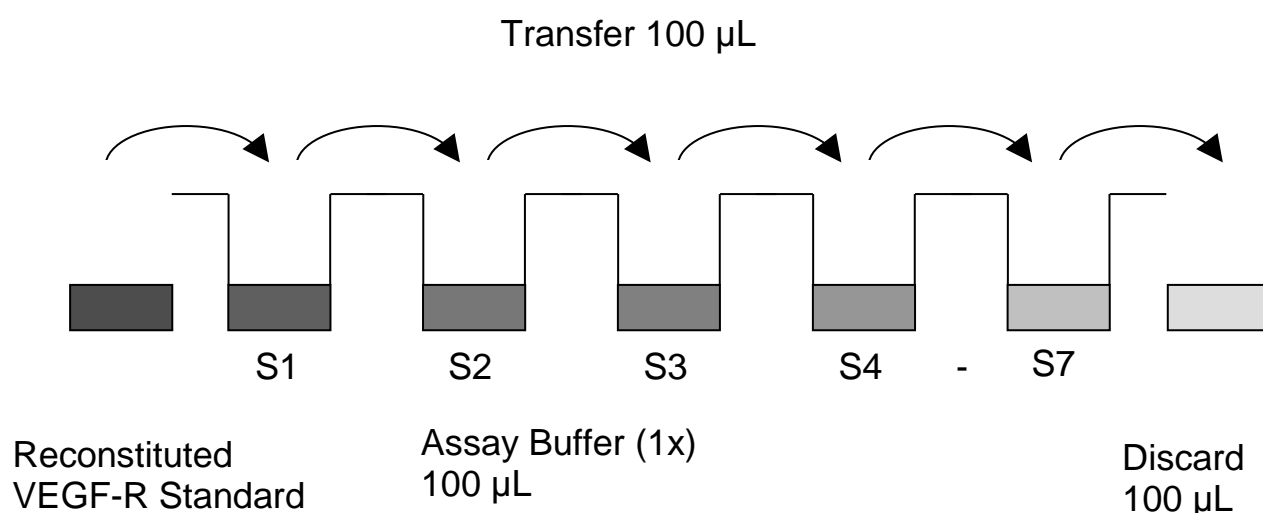

In case of an **external standard dilution** (see 9.4.1), pipette 100  $\mu$ L of these standard dilutions (S1 - S7) in the standard wells according to Table 1.

Table 1

Table depicting an example of the arrangement of blanks, standards and samples in the microwell strips:

	1	2	3	4
A	Standard 1 (10.00 ng/mL)	Standard 1 (10.00 ng/mL)	Sample 1	Sample 1
B	Standard 2 (5.00 ng/mL)	Standard 2 (5.00 ng/mL)	Sample 2	Sample 2
C	Standard 3 (2.50 ng/mL)	Standard 3 (2.50 ng/mL)	Sample 3	Sample 3
D	Standard 4 (1.25 ng/mL)	Standard 4 (1.25 ng/mL)	Sample 4	Sample 4
E	Standard 5 (0.63 ng/mL)	Standard 5 (0.63 ng/mL)	Sample 5	Sample 5
F	Standard 6 (0.32 ng/mL)	Standard 6 (0.32 ng/mL)	Sample 6	Sample 6
G	Standard 7 (0.16 ng/mL)	Standard 7 (0.16 ng/mL)	Sample 7	Sample 7
H	Blank	Blank	Sample 8	Sample 8

- d. Add 100  $\mu$ L of **Assay Buffer (1x)** in duplicate to the **blank wells**.
- e. Add 50  $\mu$ L of **Assay Buffer (1x)** to the **sample wells**.
- f. Add 50  $\mu$ L of each **sample** in duplicate to the **sample wells**.
- g. Prepare **Biotin-Conjugate** (see Preparation of Biotin-Conjugate 9.2).
- h. Add 50  $\mu$ L of **Biotin-Conjugate** to all wells.
- i. Cover with an adhesive film and incubate at room temperature (18 to 25°C) for 2 hours, if available on a microplate shaker set at 400 rpm.
- j. Prepare **Streptavidin-HRP** (refer to Preparation of Streptavidin-HRP 9.3).

- k. Remove adhesive film and empty wells. **Wash** microwell strips 6 times according to point b. of the test protocol. Proceed immediately to the next step.
- l. Add 100 µL of diluted **Streptavidin-HRP** to all wells, including the blank wells.
- m. Cover with an adhesive film and incubate at room temperature (18° to 25°C) for 1 hour, if available on a microplate shaker set at 400 rpm.
- n. Remove adhesive film and empty wells. **Wash** microwell strips 6 times according to point b. of the test protocol. Proceed immediately to the next step.
- o. Pipette 100 µL of **TMB Substrate Solution** to all wells.
- p. Incubate the microwell strips at room temperature (18° to 25°C) for about 30 min. Avoid direct exposure to intense light.

**The color development on the plate should be monitored and the substrate reaction stopped (see next point of this protocol) before positive wells are no longer properly recordable. Determination of the ideal time period for color development has to be done individually for each assay.**

It is recommended to add the stop solution when the highest standard has developed a dark blue color. Alternatively the color development can be monitored by the ELISA reader at 620 nm. The substrate reaction should be stopped as soon as Standard 1 has reached an OD of 0.9 – 0.95.

- q. Stop the enzyme reaction by quickly pipetting 100 µL of **Stop Solution** into each well. It is important that the Stop Solution is spread quickly and uniformly throughout the microwells to completely inactivate the enzyme. Results must be read immediately after the Stop Solution is added or within one hour if the microwell strips are stored at 2 - 8°C in the dark.
- r. Read absorbance of each microwell on a spectro-photometer using 450 nm as the primary wave length (optionally 620 nm as the reference wave length; 610 nm to 650 nm is acceptable). Blank the plate reader according to the manufacturer's instructions by using the blank wells. Determine the absorbance of both the samples and the standards.

**Note: In case of incubation without shaking the obtained O.D. values may be lower than indicated below. Nevertheless the results are still valid.**

## 11 Calculation of Results

- Calculate the average absorbance values for each set of duplicate standards and samples. Duplicates should be within 20 percent of the mean value.
- Create a standard curve by plotting the mean absorbance for each standard concentration on the ordinate against the human VEGF-R1 concentration on the abscissa. Draw a best fit curve through the points of the graph (a 5-parameter curve fit is recommended).
- To determine the concentration of circulating human VEGF-R1 for each sample, first find the mean absorbance value on the ordinate and extend a horizontal line to the standard curve. At the point of intersection, extend a vertical line to the abscissa and read the corresponding human VEGF-R1 concentration.
- If instructions in this protocol have been followed, samples have been diluted 1:2 (50 µL sample + 50 µL Assay Buffer (1x)) and the concentration read from the standard curve must be multiplied by the dilution factor (x 2).
- Calculation of samples with a concentration exceeding standard 1 will result in incorrect, low human VEGF-R1 levels (Hook Effect). Such samples require further external predilution according to expected human VEGF-R1 values with Assay Buffer (1x) in order to precisely quantitate the actual human VEGF-R1 level.
- It is suggested that each testing facility establishes a control sample of known human VEGF-R1 concentration and runs this additional control with each assay. If the values obtained are not within the expected range of the control, the assay results may be invalid.
- A representative standard curve is shown in Figure 8.  
Note: Do not use this standard curve to derive test results. Each laboratory must prepare a standard curve for each group of microwell strips assayed.

Figure 8

Representative standard curve for human VEGF-R1 ELISA. Human VEGF-R1 was diluted in serial 2-fold steps in Assay Buffer (1x). Do not use this standard curve to derive test results. A standard curve must be run for each group of microwell strips assayed.

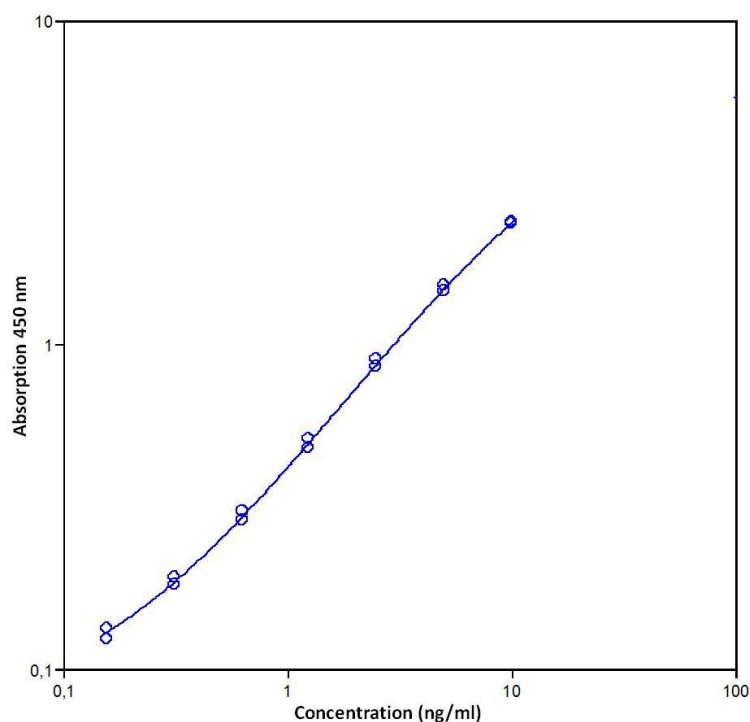

Table 2

Typical data using the human VEGF-R1 ELISA

Measuring wavelength: 450 nm

Reference wavelength: 620 nm

Standard	Human VEGF-R1 Concentration (ng/mL)	O.D. at 450 nm	Mean O.D. at 450 nm	C.V. (%)
1	10.00	2.389 2.372	2.381	0.4
2	5.00	1.458 1.518	1.488	2.0
3	2.50	0.900 0.852	0.876	2.8
4	1.25	0.511 0.480	0.496	3.1
5	0.63	0.306 0.289	0.297	3.0
6	0.31	0.191 0.181	0.186	2.9
7	0.16	0.134 0.124	0.129	3.8
Blank	0.00	0.054 0.055	0.054	1.6

The OD values of the standard curve may vary according to the conditions of assay performance (e.g. operator, pipetting technique, washing technique or temperature effects). Furthermore shelf life of the kit may affect enzymatic activity and thus color intensity. Values measured are still valid.

## 12 Limitations

- Since exact conditions may vary from assay to assay, a standard curve must be established for every run.
- Bacterial or fungal contamination of either screen samples or reagents or cross-contamination between reagents may cause erroneous results.
- Disposable pipette tips, flasks or glassware are preferred, reusable glassware must be washed and thoroughly rinsed of all detergents before use.
- Improper or insufficient washing at any stage of the procedure will result in either false positive or false negative results. Empty wells completely before dispensing fresh wash solution, fill with Wash Buffer as indicated for each wash cycle and do not allow wells to sit uncovered or dry for extended periods.
- The use of radioimmunotherapy has significantly increased the number of patients with human anti-mouse IgG antibodies (HAMA). HAMA may interfere with assays utilizing murine monoclonal antibodies leading to both false positive and false negative results. Serum samples containing antibodies to murine immunoglobulins can still be analysed in such assays when murine immunoglobulins (serum, ascitic fluid, or monoclonal antibodies of irrelevant specificity) are added to the sample.

## 13 Performance Characteristics

### 13.1 Sensitivity

The limit of detection of human VEGF-R1 defined as the analyte concentration resulting in an absorbance significantly higher than that of the dilution medium (mean plus 2 standard deviations) was determined to be 0.03 ng/mL (mean of 6 independent assays).

### 13.2 Reproducibility

#### 13.2.1 Intra-assay

Reproducibility within the assay was evaluated in 3 independent experiments. Each assay was carried out with 6 replicates of 6 serum samples containing different concentrations of human VEGF-R1. 2 standard curves were run on each plate. Data below show the mean human VEGF-R1 concentration and the coefficient of variation for each sample (see Table 3). The calculated overall intra-assay coefficient of variation was 5.5%.

Table 2

The mean human VEGF-R1 concentration and the coefficient of variation for each sample

Sample	Experiment	Mean Human VEGF-R1 Concentration (ng/mL)	Coefficient of Variation (%)
1	1	15.38	3.5
	2	14.15	5.4
	3	15.26	2.9
2	1	9.91	3.2
	2	9.16	4.6
	3	9.86	3.5
3	1	5.46	6.2
	2	5.23	2.8
	3	5.47	5.3
4	1	4.05	5.2
	2	3.71	3.9
	3	3.95	5.5
5	1	2.87	6.2
	2	2.40	4.6
	3	2.90	7.8

Sample	Experiment	Mean Human VEGF-R1 Concentration (ng/mL)	Coefficient of Variation (%)
6	1	2.15	5.9
	2	2.04	4.8
	3	2.28	5.4
7	1	0.52	2.6
	2	0.46	8.9
	3	0.50	11.8
8	1	0.82	5.4
	2	0.85	7.0
	3	0.86	8.8

### 13.2.2 Inter-assay

Assay to assay reproducibility within one laboratory was evaluated in 2 independent experiments. Each assay was carried out with 6 replicates of 6 serum samples containing different concentrations of human VEGF-R1. 2 standard curves were run on each plate. Data below show the mean human VEGF-R1 concentration and the coefficient of variation calculated on 18 determinations of each sample (see Table 3). The calculated overall inter-assay coefficient of variation was 5.1%.

Table 3

The mean human VEGF-R1 concentration and the coefficient of variation of each sample

Sample	Mean Human VEGF-R1 Concentration (ng/mL)	Coefficient of Variation (%)
1	14.93	4.5
2	9.64	4.3
3	5.39	2.5
4	3.90	4.5
5	2.72	10.4
6	2.16	5.5
7	0.49	6.5
8	0.84	2.4

### 13.3 Spike Recovery

The spike recovery was evaluated by spiking 3 levels of human VEGF-R1 into serum, plasma and cell culture supernatant. Recoveries were determined with 4 replicates each. The amount of endogenous human VEGF-R1 in unspiked samples was subtracted from the spike values. Recoveries were shown to depend on the serum used.

For recovery data see Table 5.

Table 4

Sample matrix	Spike high (%)	Spike medium (%)	Spike low (%)
Serum	46	50	67
Plasma (EDTA)	73	72	91
Plasma (citrate)	148	115	155
Cell culture supernatant	47	56	79

### 13.4 Dilution Parallelism

Serum, plasma and cell culture supernatant samples with different levels of human VEGF-R1 were analysed at serial 2 fold dilutions with 4 replicates each.

For recovery data see Table 5.

Table 5

Sample matrix	Recovery of Exp. Val.	
	Range (%)	Mean (%)
Serum	112 - 148	128
Plasma (EDTA)	114 - 142	125
Plasma (citrate)	77 - 121	102
Cell culture supernatant	105 - 127	116

### 13.5 Sample Stability

#### 13.5.1 Freeze-Thaw Stability

Aliquots of serum samples (spiked or unspiked) were stored at -20°C and thawed 5 times, and the human VEGF-R1 levels determined. There was no significant loss of human VEGF-R1 immunoreactivity detected by freezing and thawing.

#### 13.5.2 Storage Stability

Aliquots of serum samples (spiked or unspiked) were stored at -20°C, 2-8°C, room temperature (RT) and at 37°C, and the human VEGF-R1 level determined after 24 h. There was no significant loss of human VEGF-R1 immunoreactivity detected during storage at -20°C and 4°C.

A significant loss of human VEGF-R1 immunoreactivity was detected during storage at RT and 37°C.

### 13.6 Specificity

The assay detects both natural and recombinant human VEGF-R1.

The cross reactivity and interference of circulating factors of the immune system was evaluated by spiking these proteins at physiologically relevant concentrations into a human VEGF-R1 positive sample. Interference was detected for VEGF-A at concentrations > 0.15 ng/mL and for PLGF-1 at concentrations > 2.5 ng/mL.

There was no cross reactivity or interference detected for KDR, PDGFAA, PDGF-BB, VEGF-B, VEGF-C, VEGF-D, HGF, EGF.

### 13.7 Expected Values

Panels of 40 serum as well as EDTA and citrate plasma samples from randomly selected apparently healthy donors (males and females) were tested for human VEGF-R1. The levels measured may vary with the sample collection used.

Elevated human VEGF-R1 levels depend on the type of immunological disorder.

For detected human VEGF-R1 levels see Table 6.

Table 6

Sample Matrix	Number of Samples Evaluated	Range (ng/mL)	% Detectable	Mean of Detectable (ng/mL)
Serum	40	nd *- 0.42	5	--
Plasma (EDTA)	40	nd	--	--
Plasma (Citrate)	40	nd	--	--

\* n.d. = non-detectable, samples measured below the lowest standard point are considered to be non-detectable.

## 14 Reagent Preparation Summary

### 14.1 Wash Buffer (1x)

Add **Wash Buffer Concentrate 20x** (50 mL) to 950 mL distilled water.

Number of Strips	Wash Buffer Concentrate (mL)	Distilled Water (mL)
1 - 6	25	475
1 - 12	50	950

### 14.2 Assay Buffer (1x)

Add **Assay Buffer Concentrate 20x** (5 mL) to 95 mL distilled water.

Number of Strips	Assay Buffer Concentrate (mL)	Distilled Water (mL)
1 - 6	2.5	47.5
1 - 12	5.0	95.0

### 14.3 Biotin-Conjugate

Make a 1:100 dilution of **Biotin-Conjugate** in Conjugate Diluent:

Number of Strips	Biotin-Conjugate (mL)	Conjugate Diluent (mL)
1 - 6	0.03	2.97
1 - 12	0.06	5.94

### 14.4 Streptavidin-HRP

Make a 1:300 dilution of **Streptavidin-HRP** in Conjugate Diluent:

Number of Strips	Streptavidin-HRP (mL)	Conjugate Diluent (mL)
1 - 6	0.02	5.98
1 - 12	0.04	11.96

### 14.5 Human VEGF-R1 Standard

Reconstitute lyophilized **human VEGF-R1 standard** with distilled water. (Reconstitution volume is stated on the label of the standard vial.)













**15 Test Protocol Summary**

1. Determine the number of microwell strips required.
2. Wash microwell strips twice with Wash Buffer.
3. Standard dilution on the microwell plate: Add 100 µL Assay Buffer (1x), in duplicate, to all standard wells. Pipette 100 µL prepared standard into the first wells and create standard dilutions by transferring 100 µL from well to well. Discard 100 µL from the last wells. Alternatively external standard dilution in tubes (see 9.4.1): Pipette 100 µL of these standard dilutions in the microwell strips.
4. Add 100 µL Assay Buffer (1x), in duplicate, to the blank wells.
5. Add 50 µL Assay Buffer (1x) to sample wells.
6. Add 50 µL sample in duplicate, to designated sample wells.
7. Prepare Biotin-Conjugate.
8. Add 50 µL Biotin-Conjugate to all wells.
9. Cover microwell strips and incubate 2 hours at room temperature (18° to 25°C).
10. Prepare Streptavidin-HRP.
11. Empty and wash microwell strips 6 times with Wash Buffer.
12. Add 100 µL diluted Streptavidin-HRP to all wells.
13. Cover microwell strips and incubate 1 hour at room temperature (18° to 25°C).
14. Empty and wash microwell strips 6 times with Wash Buffer.
15. Add 100 µL of TMB Substrate Solution to all wells.
16. Incubate the microwell strips for about 30 minutes at room temperature (18° to 25°C).
17. Add 100 µL Stop Solution to all wells.
18. Blank microwell reader and measure color intensity at 450 nm.

**Note: If instructions in this protocol have been followed, samples have been diluted 1:2 (50 µL sample + 50 µL Assay Buffer (1x)) and the concentration read from the standard curve must be multiplied by the dilution factor (x 2).**



# Symbols / Symbole / Symbôles / Símbolos / Símbolos / Σύμβολα

	Cat.-No.: / Kat.-Nr.: / No.- Cat.: / Cat.-No.: / N.º Cat.: / N.-Cat.: / Αριθμός-Κατ.:
	Lot-No.: / Chargen-Bez.: / No. Lot: / Lot-No.: / Lote N.º: / Lotto n.: / Αριθμός -Παραγωγή:
	Use by: / Verwendbar bis: / Utiliser à: / Usado por: / Usar até: / Da utilizzare entro: / Χρησιμοποιείται από:
	No. of Tests: / Kitgröße: / Nb. de Tests: / No. de Determ.: / N.º de Testes: / Quantità dei tests: / Αριθμός εξετάσεων:
	Concentrate / Konzentrat / Concentré / Concentrar / Concentrado / Concentrato / Συμπύκνωμα
	Lyophilized / Lyophilisat / Lyophilisé / Liofilizado / Liofilizado / Liofilizzato / Λυοφιλιασμένο
	In Vitro Diagnostic Medical Device. / In-vitro-Diagnostikum. / Appareil Médical pour Diagnostics In Vitro. / Dispositivo Médico para Diagnóstico In Vitro. / Equipamento Médico de Diagnóstico In Vitro. / Dispositivo Medico Diagnostico In vitro. / Ιατρική συσκευή για In-Vitro Διάγνωση.
	Evaluation kit. / Nur für Leistungsbewertungszwecke. / Kit pour évaluation. / Juego de Reactivos para Evaluació. / Kit de avaliação. / Kit di evaluazione. / Κιτ Αξιολόγησης.
	Read instructions before use. / Arbeitsanleitung lesen. / Lire la fiche technique avant emploi. / Lea las instrucciones antes de usar. / Ler as instruções antes de usar. / Leggere le istruzioni prima dell'uso. / Διαβάστε τις οδηγίες πριν την χρήση.
	Keep away from heat or direct sun light. / Vor Hitze und direkter Sonneneinstrahlung schützen. / Garder à l'abri de la chaleur et de toute exposition lumineuse. / Manténgase alejado del calor o la luz solar directa. / Manter longe do calor ou luz solar directa. / Non esporre ai raggi solari. / Να φυλάσσεται μακριά από θερμότητα και άμεση επαφή με το φως του ηλίου.
	Store at: / Lagern bei: / Stocker à: / Almacene a: / Armazemar a: / Conservare a: / Αποθήκευση στους:
	Manufacturer: / Hersteller: / Fabricant: / Productor: / Fabricante: / Fabbicante: / Παραγωγός:
	Caution! / Vorsicht! / Attention! / ¡Precaución! / Cuidado! / Attenzione! / Προσοχή!
<p>Symbols of the kit components see MATERIALS SUPPLIED.</p> <p>Die Symbole der Komponenten sind im Kapitel KOMPONENTEN DES KITS beschrieben.</p> <p>Voir MATERIEL FOURNI pour les symbôles des composants du kit.</p> <p>Símbolos de los componentes del juego de reactivos, vea MATERIALES SUMINISTRADOS.</p> <p>Para símbolos dos componentes do kit ver MATERIAIS FORNECIDOS.</p> <p>Per i simboli dei componenti del kit si veda COMPONENTI DEL KIT.</p> <p>Για τα σύμβολα των συστατικών του κιτ συμβουλευτείτε το ΠΑΡΕΧΟΜΕΝΑ ΥΛΙΚΑ.</p>	

**COMPLAINTS:** Complaints may be submitted initially written or vocal. Subsequently they need to be filed including the test performance and results in writing in case of analytical reasons.

**WARRANTY:** The product is warranted to be free from material defects within the specific shelf life and to comply with product specifications delivered with the product. The product must be used according to the Intended use, all instructions given in the instructions for use and within the product specific shelf life. Any modification of the test procedure or exchange or mixing of components of different lots could negatively affect the results. These cases invalidate any claim for replacement.

**LIMITATION OF LIABILITY:** IN ALL CIRCUMSTANCES THE EXTENT OF MANUFACTURER'S LIABILITY IS LIMITED TO THE PURCHASE PRICE OF THE KIT(S) IN QUESTION. IN NO EVENT SHALL MANUFACTURER BE LIABLE FOR ANY INCIDENTAL OR CONSEQUENTIAL DAMAGES, INCLUDING DAMAGES FOR LOST PROFITS, LOST SALES, INJURY TO PERSON OR PROPERTY OR ANY OTHER INCIDENTAL OR CONSEQUENTIAL LOSS.

	<b>IBL International GmbH</b>	Tel.: + 49 (0) 40 532891 -0 Fax: -11
	Flughafenstr. 52A, 22335 Hamburg, Germany	E-MAIL: IBL@IBL-International.com
		WEB: <a href="http://www.IBL-International.com">http://www.IBL-International.com</a>